

DANIEL PUENTE ENCINA



PATCHLIST

Subject to modifications and errors. We reserve the right to make instrumental changes if necessary.

Canal	Instrument	Micro
1	Dobro/Electric guitar	Sennheiser e906 (Guit. Amp)
2	Main voice	Sennheiser MD 431
3	Conga	Sennheiser MD 421
4	Tumba	Sennheiser MD 421
5	Percussion OH L	AKG 414
6	Percussion OH L	AKG 414
7	Cajon front	Audio Technica ATM350 / AKG C 518 M
8	Cajon back	Audio Technica ATM350 / AKG C 518 M
9	Cymbal OH	AKG 414
10	Trumpet	Sennheiser MD 431

BACKLINE

Guitar	Electric amp	Fender 59 Bassman Vox AC 30 Orange Thunder 30c Mandatory Tube Amplifier 30 watts /Fender Mustang III		
	Chair	Chair without armrests		
	Monitor	Single mix		
	Percussion	Cajón	Meinl Artisan edition Pepote profesional edition Schlagwerk fineline serie Mandatory: Wooden Cajon	
			Conga	1 Conga 11 3/4" LP Galaxy Giovanni serie LP Classic Meinl LC1134NT-M Luis Conte Mandatory: Wooden Conga
Tumba				1 Tumba 11" LP Galaxy Giovanni serie or LP Classic LP Classic Meinl LC11NT-M Luis Conte Mandatory: Wooden Quinto
				Cowbell Cha cha
		Cowbell Bongo	1 LP ES-8 Salsa bongo Meinl RM80B Meinl STB625HH-G Mandatory: Professional Cowbell	

DANIEL PUENTE ENCINA



	Tambourine	LP Mountable Cyclops Tambourine
	Bongos	Bongos if available
	Cymbal	14 K-Custom fast crash (Thincrash) 14 Paiste signature fast crash 14 Crash (Thincrash)
	2 x Cymbal Stand	Cymbal stand DW 5700 Pearl BC-1030 Cymbal Booms Stand Tama HC33BW Cymbal Boom Stand Mandatory: Standard Professional Boom Stand
	Monitor	Single mix
Brass	Trumpet	
	Monitor	Single mix

Light requirements

Just inspiration - you are welcome to do better than that :-)

Please NO permanently pink, purple, or green on faces to avoid the musicians look sick or like pigs.

Please avoid vertical spots directly from above that focus the hair (looks weird).

Front truss:	4 – 6 Fresnel lenses 4 – 6 LED Washer 4 Par 64 cp 62, c.t. 201 4 Par 64 cp 62, amber 135 4 Par 64 cp 62, magenta 126 4 Par 64 cp 62, blue 119
Back truss	6 Moving spot 6 LED Washer 1 - 2 ACL Sets // c.t. 201 (Par 36 or Par 64) center and side 4 Par 64 cp 60, magenta 126 4 Par 64 cp 60, aquamarine 115 4 Par 64 cp 60, blue 119
Backfloor:	2 Hazer
Floor:	6 LED Floorlights



Stage

Subject to modifications and errors. We reserve the right to make technical changes if necessary.

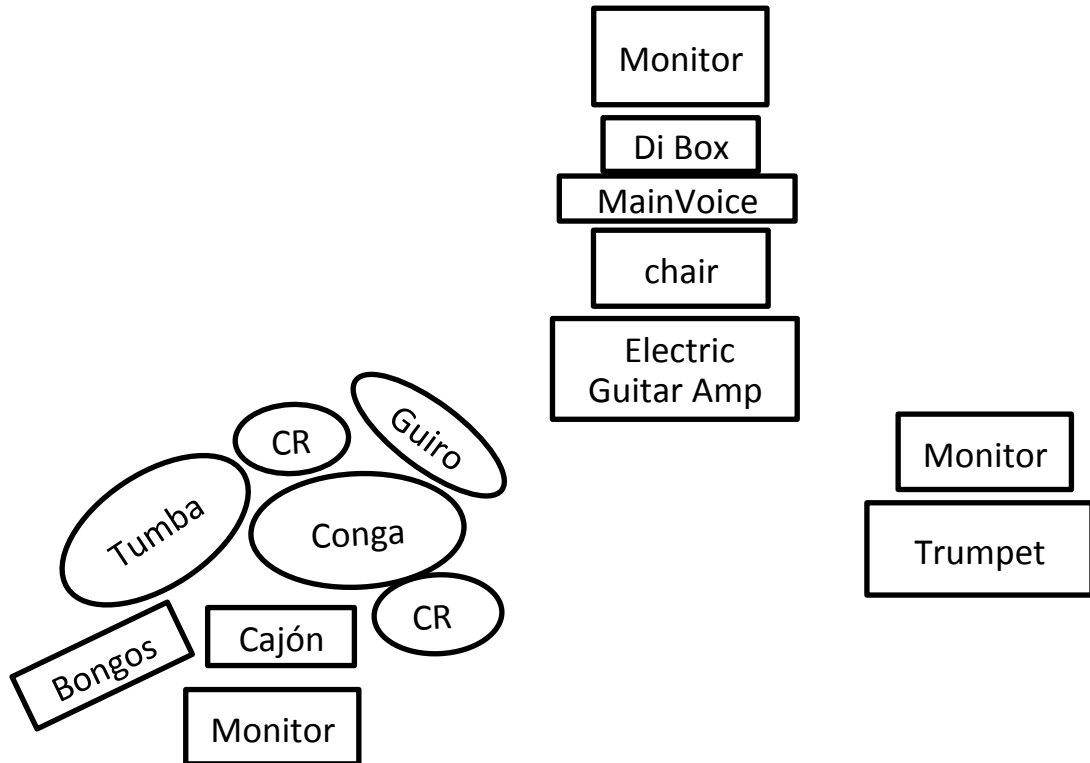

Soundbriefing

General Sound: World Music

Please NO dub delays

Percussion: Natural sound / Rumba-Cubana-Afro-Music

Please give him/her enough monitor of him/herself.

The lowest frequencies of the Cajon it's about 150 Mhz.

Please don't add Sub-bass frequencies at it.

The congas need enough treble to produce the Marcha (the Groove).

Please be careful with the Middles (and basses)

Electric Guitar:

Please don't add too much compression. Clean and natural sound with a little reverb.

Voice (principal melody):

Clear sound without delays or any other effects.

Add some Reverb in the monitor, please.