

# TECH RIDER

**DEVADO<sup>G</sup>**  
JUST VOCALS & BODY PERCUSSION

Version 5.0 23.01.2024

# Equipment

## Provided by Artist

- Mic:
  - Shure KSM 9
- InEar Monitoring:
  - Fischer Amps Belt Pack
    - Standard: Mono Mix comes from DEVADOS Audio Interface
    - Backup: Mix: Mono Mix (Vocals, Backing Tracks, Talkback)
- Mac book + Audio Interface (Vocal Chain / FX 1 / FX2 / Backing Tracks / Samples):
  - OUT (XLR sym.)
    - Output 1: Backing Tracks le
    - Output 2: Backing Tracks ri
    - Output 3: DEVADO (Vocal Chain: Gate + Autotune + Low Cut/EQ + Compressor)
    - Output 4: DEVADO FX 1 (Reverb)
    - Output 5: DEVADO FX 2 (Delay)
    - Output 6: DEVADO (Backup: Vocal „direct out“)
  - IN (XLR sym.)
    - Input 1: Talk Back from FOH

# Equipment

## Provided by Location

- XLR Cable (Length based on Stage Size):
  - 3 x for DEVADO
  - 2 x for Backing Tracks
  - 2 x Backup (min)
- Mic Stand with Shure Clamp
- Power Plug (Length based on Stage Size):
  - 1 x Stage Rack (Audio Interface + WIFI + MacBook)
- Batteries:
  - 2 x 9V block
- Backup - Mic:
  - 1 x Mic (z.B. Shure KSM9, Shure Beta 58)
- Backup – Monitoring:
  - 1 x Wireless InEar – mono (if available instead of Fischer Amps / Stage Monitoring)
  - 1 x Stage monitoring (if using InEar --> muted)
- Backup - Audio Interface: DI Boxes + Wiring (Backing Tracks):
  - 2 x DI Boxes
  - 1 x Mini jack stereo → 2x Mono Jack

# SIGNAL FLOW

## Interface

DEVADO

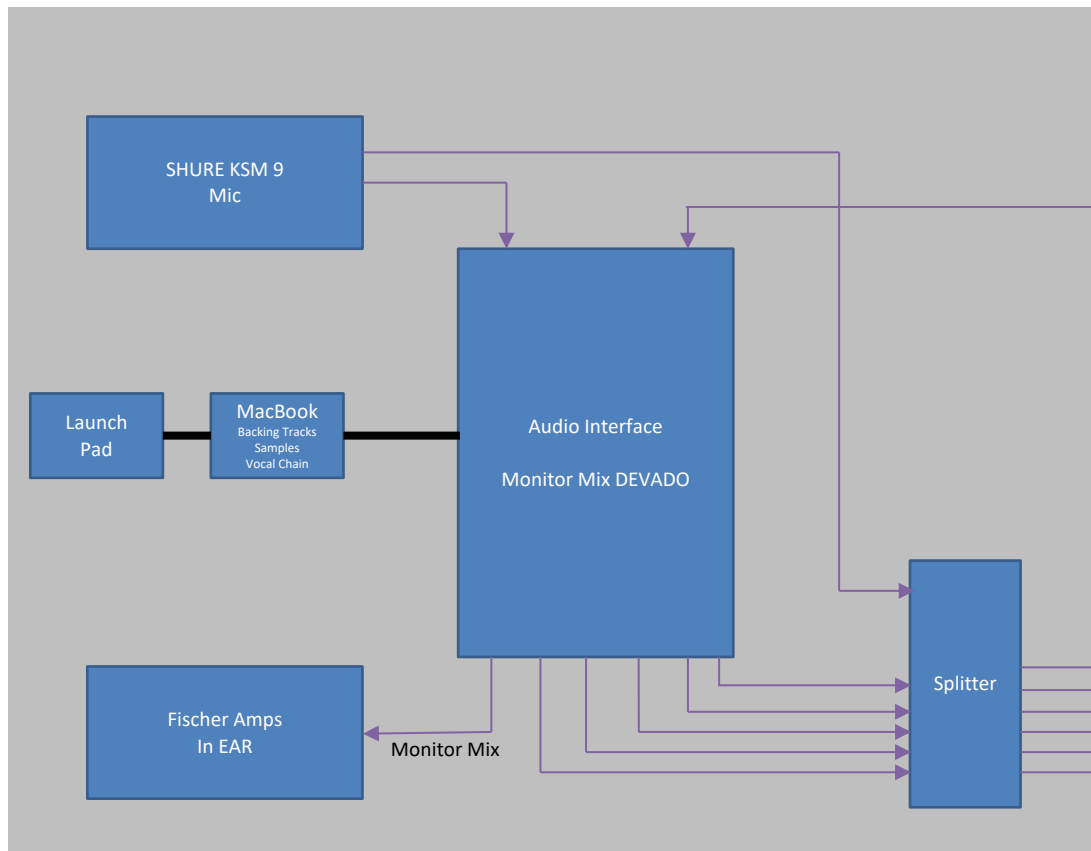

FOH

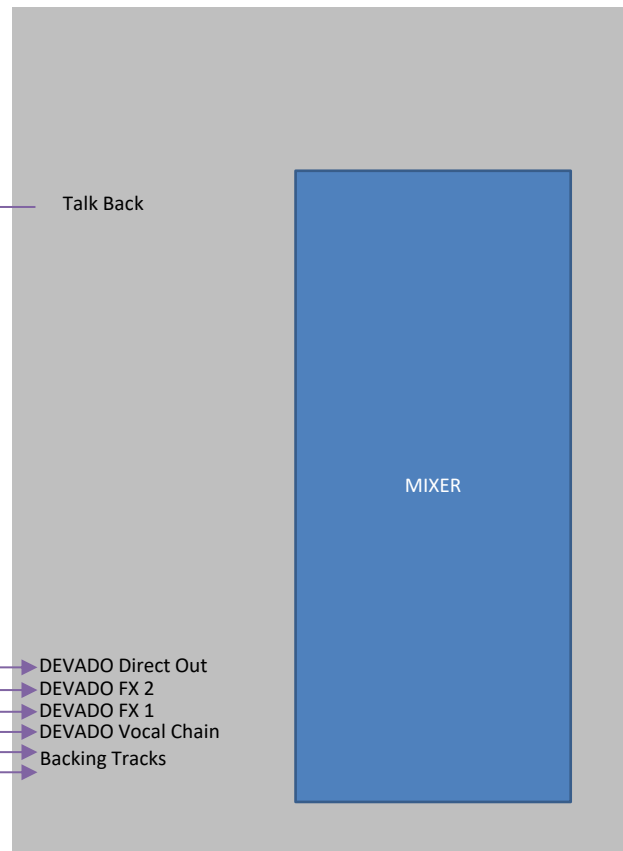

# Stage

## Concept sketch

View from FOH

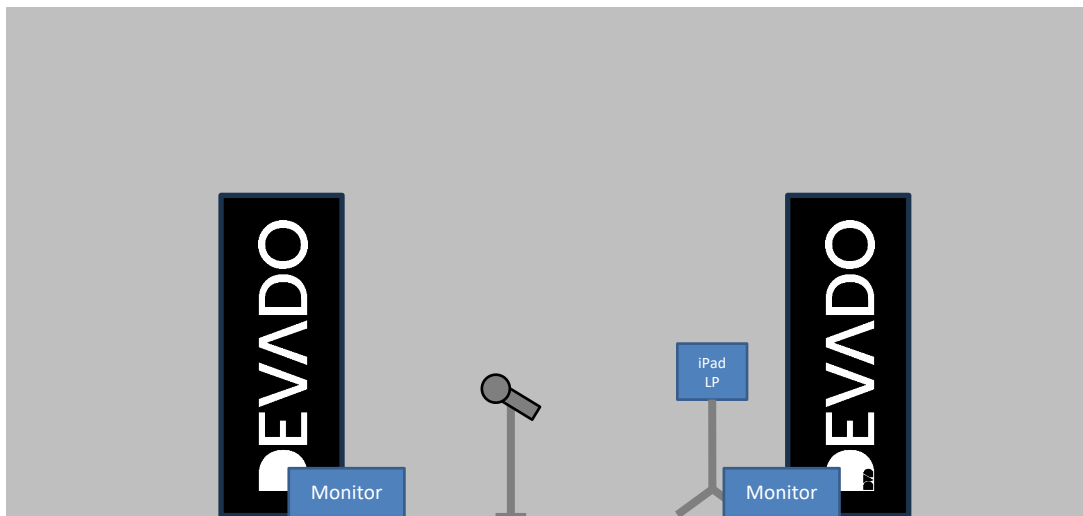

Birds View

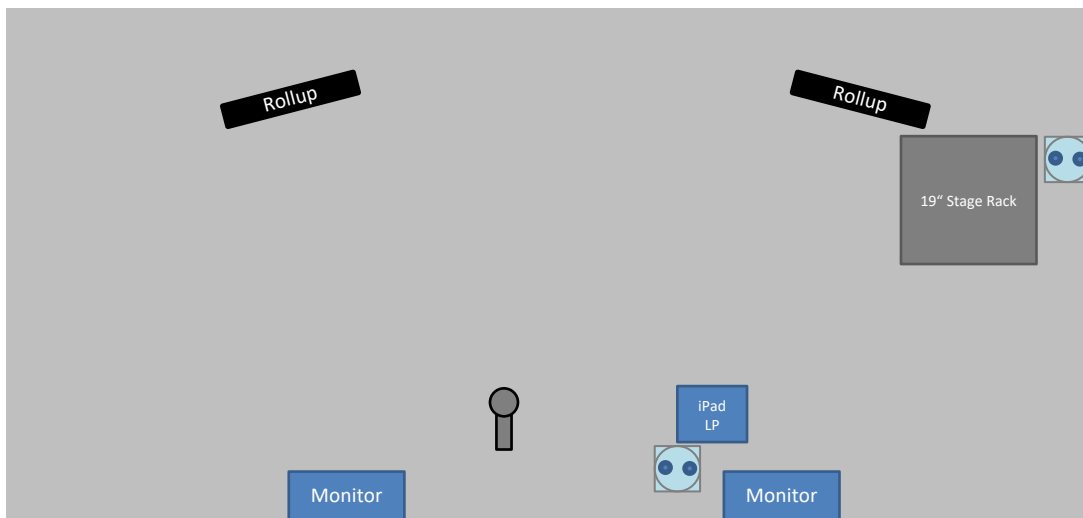

Power Plug: 

# Contact

## Common

Telephone: +49 176 220 79367

Email: [info@devadomusic.com](mailto:info@devadomusic.com)