

AGE OF GLASS

Technical Rider: May 2014

| Channel No | Instrument | Mic / DI | Stand | Insert |
|------------|-------------------------|--------------|-------|--------|
| 1 | Drums L | XLR out * | | Comp |
| 2 | Drums R | XLR out * | | Comp |
| 3 | Kick | XLR out * | | Comp |
| 4 | Snare | XLR out * | | Comp |
| 5 | Samples L | XLR out * | | Comp |
| 6 | Samples R | XLR out * | | Comp |
| 7 | Bass Clean | DI | | Comp |
| 8 | Bass FX | DI | | |
| 9 | Bass Novation Synth | DI | | Comp |
| 10 | Roland SPDS | DI | | |
| 11 | Acoustic Gtr | XLR out | | |
| 12 | Virus Synth L | DI | | Comp |
| 13 | Virus Synth R | DI | | Comp |
| 14 | Nord Synth L | DI | | Comp |
| 15 | Nord Synth R | DI | | Comp |
| 16 | Nick Vocal | SM58 | Tall | Comp |
| 17 | Rory Vocal Dry (main) | SM58 XLR Out | Tall | Comp |
| 18 | Rory Vocal Wet FX Split | XLR Out | Tall | |
| 19 | Stan Vocal | SM58 | Tall | Comp |
| 20 | Spare Vocal | SM58 | Tall | Comp |
| 21 | Reverb Return | N/A | N/A | N/A |

*Output from an Audio Interface. All (#) lines are balanced XLR output.

Age of Glass - Stage Plan:

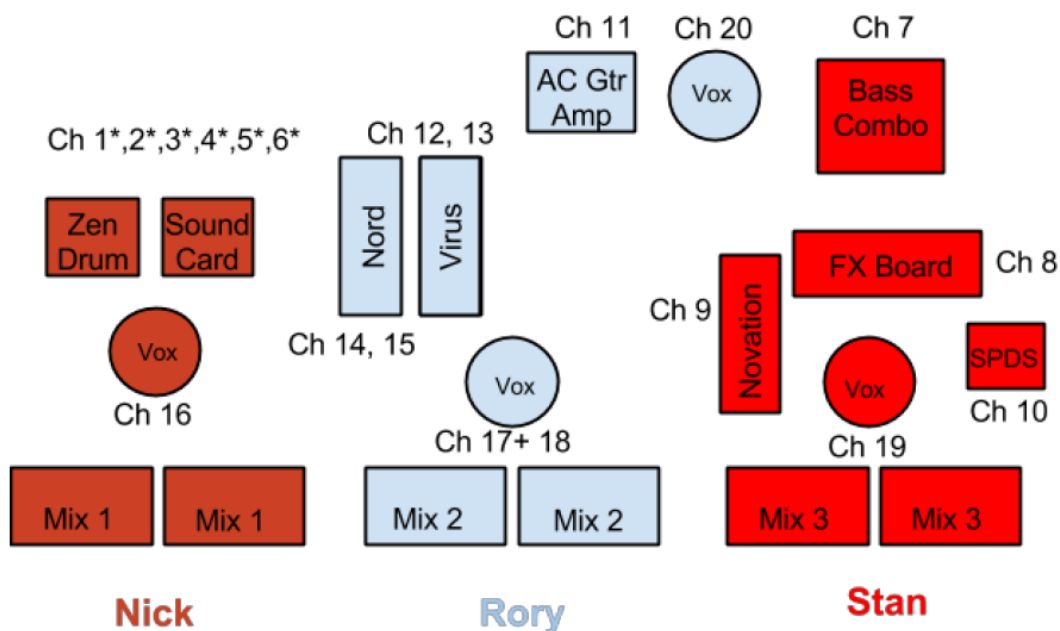

Touring Party:

Rory: Synths, Guitar, Lead Vocal

Nick: Zen Drum, Samples, Backing Vocals

Stan: Bass Guitar, Backing Vocals

Jonny: FOH Engineer - all tech enquires send to

Jonny@neuronproaudio.co.uk or call 07894271605

PA Requirements:

Age of Glass are an electronic dance music act. The PA system must be of adequate power for the intended space with separate sub and mid high cabinets. It must have adequate headroom for live music. The music is very bass driven therefore subs must be of suitable size for the intended space.

FOH Requirements:

FOH console can be either analogue or digital.

Preferred digital consoles (in order of preference):

Soundcraft Vi or Si

Midas Pro

Yamaha M7 / LS9 (NO 01V / 03D!!!)

Behringer X32

Preferred analogue consoles (in order of preference):

Midas

Allen & Heath

Soundcraft

NO MACKIE, ALTO, PHONIC, BEHRINGER OR YAMAHA please.

If an analogue console is to be used please ensure that adequate outboard units are provided. We ideally require 12 channels of compression although can be flexible if needed to be. Brands: DBX, Klark Teknik, Audient, LA Audio all fine. Please **NO BEHRINGER etc.**

Monitoring Requirements:

We require a minimum of three separate monitor mixes on stage. ALL mixes MUST have 31 band graphic EQ inserted on the aux send. Ideally each mix should feature a pair of wedges but at a bare minimum mix two (centre vocal) must feature a pair. Wedges should ideally be passive and bi-amped with control for Mid and HF sections of the cabinet, preferably no active speakers. Each speaker should be a minimum of 450 watt RMS. Ideally wedges should be rung out before arrival in order to avoid any feedback issues.

N.B. We are a very approachable bunch of souls, if you cannot meet the requirements stipulated on this rider then please JUST LET US KNOW.

100% preparation = 0% perspiration :-) Thanks in advance, **A.O.G**